

**RESIDENTIAL WASTEWATER TREATMENT SYSTEMS -NITROGEN REDUCTION  
STANDARD 245 - 2019  
PERFORMANCE TESTING AND EVALUATION**

## **8 Performance testing and evaluation**

This section describes the methods used to evaluate the performance of residential wastewater treatment systems designed to remove nitrogen from residential wastewater. Performance testing and evaluation shall not be restricted to specific seasons.

### **8.1 Preparations for testing and evaluation**

8.1.1 The system shall be assembled, installed, and filled in accordance with the manufacturer's instructions.

8.1.2 The manufacturer shall inspect the system for proper installation. If no defects are detected and the system is judged to be structurally sound, it shall be placed into operation in accordance with the manufacturer's start-up procedures. If the manufacturer does not provide a start-up procedure, 2/3's of the system's capacity shall be filled with water and the remaining 1/3 shall be filled with residential wastewater.

8.1.3 The system shall undergo design loading (see 8.2.2.1) until testing and evaluations are initiated. Sample collection and analysis shall be initiated within three weeks of filling the system and shall continue without interruption until the end of the evaluation period, except as specified in 8.4.2.

8.1.4 If conditions at the test site preclude installation of the system at its normally prescribed depth, the manufacturer shall be permitted to cover the system with soil to achieve normal installation depth.

8.1.5 Performance testing and evaluation of systems shall not be restricted to specific seasons.

8.1.6 When possible, electrical or mechanical defects shall be repaired to prevent delays. All repairs made during the performance testing and evaluation shall be documented in the final report.

8.1.7 The system shall be operated in accordance with the manufacturer's instructions. However, routine service and maintenance of the system shall not be allowed during the testing and evaluation period.

**NOTE** -The manufacturer may recommend or offer more frequent service and maintenance of the system, but for purpose of performance testing and evaluation, the service and maintenance shall not be performed beyond what is specified in this Standard.

8.1.8 Prior to the initiation of design loading, the air delivery component (if one is utilized) – either air compressor or blower – shall be connected to the system and run for a minimum of four hours. Air pressure shall be measured by a pressure gauge installed near the exhaust port of the air delivery component and that reading recorded.

8.1.9 When it is not possible to measure pressure on the system under test, the measurement may be completed with a separate air delivery component plumbed to a different tank. All plumbing and air distribution components used in the tested system shall be installed with the air delivery component. Potable water or wastewater shall be used. Air distribution outlets or diffusers shall be located at the same depth as in the tested system. The air delivery component shall be run for a minimum of four hours. Air pressure shall be measured by a pressure gauge installed near the exhaust port of the air delivery component and that reading recorded.

8.1.10 Following the pressure measurement, a separate air delivery component shall be tested for flow. This air delivery component shall be plumbed into the rig diagrammed below. After adjusting the backpressure to the pressure measured in Section 8.1.8 or 8.1.9, the air delivery component shall run for a minimum of 4 hours. After the 4 hour minimum run time, backpressure shall be adjusted if needed to match pressure measured in Section 8.1.8 or 8.1.9, and then flow shall be measured and recorded.

**RESIDENTIAL WASTEWATER TREATMENT SYSTEMS -NITROGEN REDUCTION  
STANDARD 245 - 2019  
PERFORMANCE TESTING AND EVALUATION**

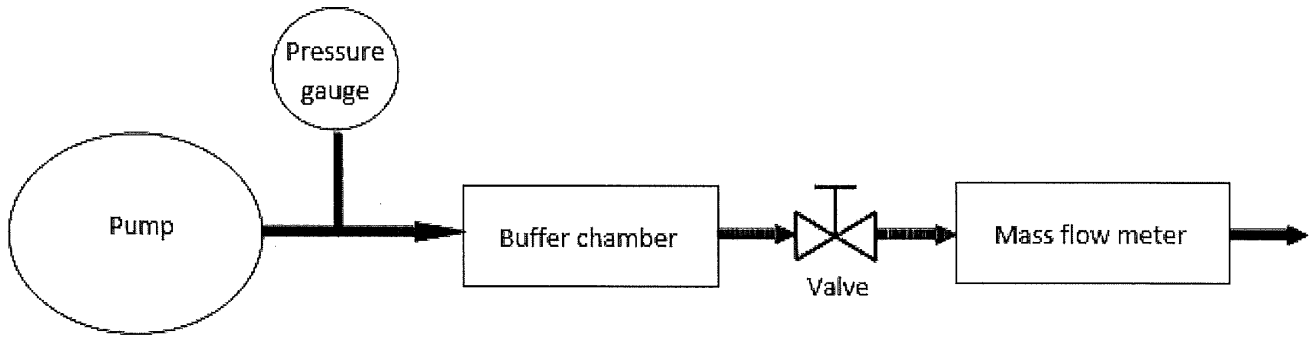

**8.2 Testing conditions, hydraulic loading and schedules**

**8.2.1 Influent wastewater characteristics**

Except as required by NSF/ANSI 40 for systems seeking concurrent NSF/ANSI 40 and Nitrogen Reduction certification, the average wastewater characteristics delivered to the system over the course of the testing shall fall within:

- BOD5 - 100 to 300 mg/L
- TSS - 100 to 350 mg/L
- TKN - 35 to 70 mg/L as N
- Alkalinity - > 175 mg/L as CaCO<sub>3</sub> (alkalinity may be adjusted if inadequate)
- Temperature - 10 to 30°C
- pH - 6.5 to 9 SU

Unless requested by the manufacturer, the raw influent shall be supplemented with sodium bicarbonate if the wastewater is found to be deficient in alkalinity. In addition, the influent shall be supplemented with urea to meet the required influent TKN concentration. The influent may also be supplemented with methanol to maintain a carbon:nitrogen ratio of no less than 5:1.

**NOTE** - For this testing, minimum alkalinity may be calculated as described in Annex A. If the influent temperature drops below 10 °c, impacting the nitrification process, sample collection may be suspended until the influent temperature returns to 10°C.

**8.2.2 Hydraulic loading**

The performance of the system shall be evaluated for a minimum of 26 wks. During the testing and evaluation period, the system shall be subjected to 16 wks of design loading, followed by 7.5 weeks (52 days) of stress loading, and an additional period of design loading to obtain a minimum of 55 influent and effluent data sets collected during non-stress dosing period.

**8.2.2.1 Design loading**

The system shall be dosed 7 days per week with a wastewater volume equivalent to the daily hydraulic capacity of the system. The following schedule shall be adhered to for dosing:

Time Frame	Approximate % Rated Daily Hydraulic Capacity
6 AM to 9 AM	35
11 AM to 2 PM	25
5 PM to 8 PM	40

**NOTE** -An individual dose shall be no more than 10 gal, unless the dosage system is based on a continuous flow, and the doses shall be uniformly applied over the dosing period.

# RESIDENTIAL WASTEWATER TREATMENT SYSTEMS -NITROGEN REDUCTION STANDARD 245 - 2019 PERFORMANCE TESTING AND EVALUATION

## 8.2.2.2 Stress loading

Stress loading sequences shall begin in week 17 of the testing and will be completed in the order listed in the following sections. Each stress sequence shall be separated by 7-d of design loading, as described in 8.2.2.1.

### 8.2.2.2.1 Wash-day stress

The wash-day stress shall consist of 3 wash-days in a 5-d period. Each wash-day shall be separated by a 24-h period. During a wash-day, the system shall be loaded at times and capacities similar to those delivered during design loading (see 8.2.2.1). However, during the first two dosing periods per day, the design loading shall include 3 wash loads (3 wash cycles and 6 rinse cycles).

### 8.2.2.2.2 Working-parent stress

For five consecutive days, the system shall be subjected to a working-parent stress. During this stress, the system shall be dosed with 40% of its daily hydraulic capacity between 6:00 a. m. and 9:00 a. m. Between 5:00 p. m. and 8:00 p. m., the system shall be dosed with the remaining 60% of its daily hydraulic capacity, which shall include 1 wash load (1 wash cycle and 2 rinse cycles).

### 8.2.2.2.3 Power/equipment failure stress

Power/equipment failure stress simulation shall consist of a flow pattern where approximately 40% of the total daily flow is received between 5 p. m. and 8 p. m. on the day when the power/equipment failure stress is initiated. Power to the system shall then be turned off at 9 p. m. and the flow pattern shall be discontinued for 48 h. After the 48-h period, power shall be restored, and the system shall receive approximately 60% of the total daily flow over a 3-h period which shall include 1 wash load (1 wash cycle and 2 rinse cycles).

### 8.2.2.2.4 Vacation stress

Vacation stress simulation shall consist of a flow pattern where approximately 35% of the total daily flow is received between 6 a. m. and 9 a. m. and approximately 25% of the total daily flow is received between 11 a.m. and 2 p. m. on the day that the vacation stress is initiated. The flow pattern shall be discontinued for 8 consecutive days with power continuing to be supplied to the system. Between 5 p. m. and 8 p. m. of the ninth day, the system shall receive 60% of the total daily flow, which shall include 3 wash loads (3 wash cycles and 6 rinse cycles).

## 8.2.3 Dosing volumes

The 30-d average volume of the wastewater delivered to the system shall be within  $100\% \pm 10\%$  of the system's rated hydraulic capacity.

**NOTE** -All dosing days, except those with dosing requirements less than the daily hydraulic capacity, shall be included in the 30-d average calculation.

## 8.3 Sample collection

### 8.3.1 Sampling frequency

Influent and effluent samples shall be collected three times per week during design loading periods and twice during each stress recovery period (the week following completion of each of the stress simulations described in 8.2.2.2). This schedule shall be continued in the event that testing is extended beyond the 26-wk minimum.

### 8.3.2 Collection methods

All sample collection shall be in accordance with APHA's *Standard Methods for the Examination of Water and Wastewater*, unless otherwise specified. Influent wastewater samples shall be flow-proportional, 24-h composites obtained during periods of system dosing. Effluent samples shall be flow-proportional, 24-h composites obtained

# RESIDENTIAL WASTEWATER TREATMENT SYSTEMS -NITROGEN REDUCTION STANDARD 245 - 2019 PERFORMANCE TESTING AND EVALUATION

during periods of system discharge. Effluent samples shall be representative of all treated effluent discharged from the system, as sampled from a central point of collection of all treated effluent. Grab samples shall be collected for pH, temperature, and dissolved oxygen (DO). The location of the grab sample shall be appropriate to provide a sample that is representative of the influent or effluent and shall be determined in conjunction with the manufacturer.

### 8.3.3 Analyses

Analyses samples collected as described in 8.3.1 and 8.3.2 shall be analyzed as follows:

Parameter	Sample Type	Sample Location		Testing Location
		Raw Influent	Treated Effluent	
BOD <sub>5</sub>	24 h composite	X	-	Laboratory
CBOD <sub>5</sub>	24 h composite	-	X	Laboratory
Total Suspended Solids	24 h composite	X	X	Laboratory
pH	Grab	X	X	Test Site
Temperature °C	Grab	X	X	Test Site
Dissolved Oxygen	Grab	-	X	Test Site
Alkalinity	24 h composite	X	X	Laboratory
TKN (as N)	24 h composite	X	X	Laboratory
Ammonia-N (as N)	24 h composite	X	X	Laboratory
Nitrite/Nitrate (as N)	24 h composite	X	X	Laboratory

### 8.3.4 Analytical Methods

The appropriate methods in APHA's *Standard Methods* shall be used to complete the analyses indicated in 8.4.3.

### 8.3.5 Pressure and flow

Air pressure shall be measured using a gauge with accuracy of 2% or better. Airflow shall be measured using a flow meter with accuracy of 10% or better.

## 8.4 Criteria

### 8.4.1 Testing conditions

If conditions during the testing and evaluation period result in system upset, improper sampling, improper dosing, or influent characteristics outside the ranges specified in 8.2.1, an assessment shall be conducted to determine the extent to which these conditions adversely affected the performance of the system. Based on this assessment, specific data points may be excluded from the averages'. Rationale for all data exclusions shall be documented in the final report.

### 8.4.2 Catastrophic site problems

In the event that a catastrophic site problem not described in the Standard including, but not limited to, influent characteristics, malfunctions of test site apparatus and acts of God, jeopardizes the validity of the performance testing, manufacturers shall be given the choice to:

- Perform maintenance on the system, reinitiate system start-up procedures, and restart the performance testing; or
- With no routine maintenance performed, have the system brought back to pre-existing conditions and resume testing within 3 wks after the site problem has been identified and corrected. Data collected during the system recovery period shall be excluded from the effluent averages.

# RESIDENTIAL WASTEWATER TREATMENT SYSTEMS -NITROGEN REDUCTION STANDARD 245 - 2019 PERFORMANCE TESTING AND EVALUATION

**NOTE** -"Pre-existing conditions" shall be defined as the point when the results of 1 wk's worth of sampling are within 15% of the averages of the samples from the previous 3 wks of sampling.

## 8.4.3 Effluent quality

For purposes of determining system performance, only samples collected during design loading periods, described in 8.2.2, shall be used in the calculations. The data collected during the stress sequences shall not be included in the calculations but shall be included in the final report.

### 8.4.3.1 CBODs

The average CBOD5 of all effluent samples shall not exceed 25 *mg/L*.

### 8.4.3.2 TSS

The average TSS of all effluent samples shall not exceed 30 *mg/L*.

### 8.4.3.3 Total nitrogen

The average total nitrogen concentration of all effluent samples shall be less than 50% of the average total nitrogen concentration of all influent samples.

### 8.4.3.4 pH

The pH of individual effluent samples shall be between 6.0 and 9.0 SU.

## 8.5 Final report

A final report shall be prepared that presents the following:

- All data collected in accordance with the testing and evaluations within this Standard;
- A table indicating the actual percent reduction over the course of the test (included in the Executive Summary, as well as in the body, of the report);
- Observations made during the testing;
- An estimation of the pounds of nitrogen loaded during the test and the pounds removed;
- A copy of the current edition of the Owner's Manual; and Process description and detailed dimensioned drawings of the system evaluated.

A supplemental report shall be prepared for any system(s) approved under the performance classification section (1.4) of this Standard, including process description(s) and dimensioned drawings.